

the NEW Cartar FLS mobile Lift

the new Cartar "FLS mobile " lift range has a drive on ground height of no more than 115 mm (4.5 inches)

the Cartar Mobile Lift increases your workshop "FLOORSPACE" profit beyond whats possible with conventional 2 and 4 post hoist.

the Cartar Mobile Lift offers a System for the flow and movement of damaged and immobile vehicles through your workshop

Welcome to a new world in
automotive workshop management

Head Office
Australia

Email : info@cartar.com.au
Skype : cartar1
www.cartar.com.au
www.cartarmobilelifts.com

Cartar Industries
P.O Box 90
Mt.Martha
Vic 3934
Australia

tel : +61 3 59 87 1514
ABN 78 884 276 079



Service and warranty
Two year warranty covers parts and labour .
Excludes air-lines. Warranty will not apply if
operating and service instructions are not followed





series : **CARTAR**
“FLS mobile”

“Lift and Move”

Benefits :

- 1/ The Cartar FL Mobile gets the tradesperson off his knees and out from lying under cars and offers a safe and comfortable working position.
- 2/ The Cartar FL Mobile offers a safe and cost effective System for moving damaged or immobile vehicles through the repair process to completion
- 3/ The Cartar FL Mobile Increases the earning capacity of your factory floor space beyond the conventional 2 and 4 post lifts



- CE Approval
- Swing Arm Locks
- Two Year Warranty
- Patented Cartar Castor
- Multiple Safety Features
- Onboard Power Pac + Oil Tank
- 115mm /4.5 inches ground height
- Patented Wheel Elevation System
- High Quality 125mm,5 inch wheels
- Weather Resistant - Inside or Outside
- Australian Manufactured and Assembled
- No expensive electrical / installation costs
- Wheels of Cast Nylon - 1 ton per wheel Rated
- Winner of many innovation and Safety Awards
- Used by all major Auto Brands around the globe



"Coke Cola NOT supplied"



Swing Arm Lock



Control Pad

series : **CARTAR**
"FLS mobile"

Benefits :

- 1/ The Cartar FLS Mobile is part of the new family of "Intellegent Lifts" The FLS mobile can be a fixed unit in a work bay. . Now add the Cartar Working Plateform and you have an elevated work bench , that is mobile with a pay load of 2800 kg. You Choose.
- 2/ The Cartar FLS mobile gets the tradesperson off his knees and out from lying under cars and offers a safe and comfortable working position.

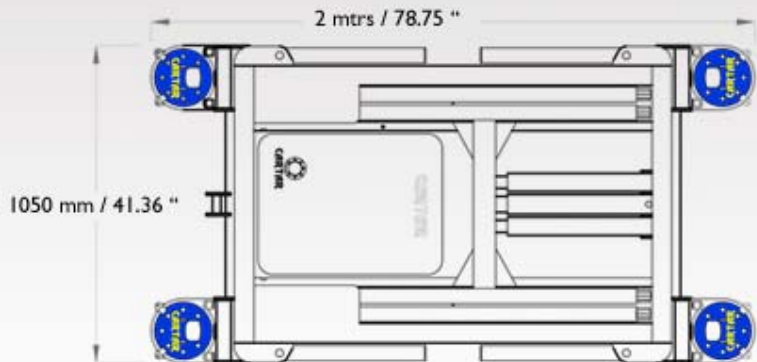
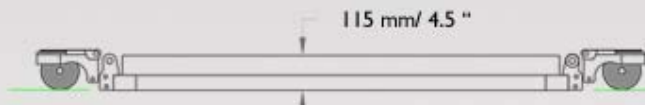
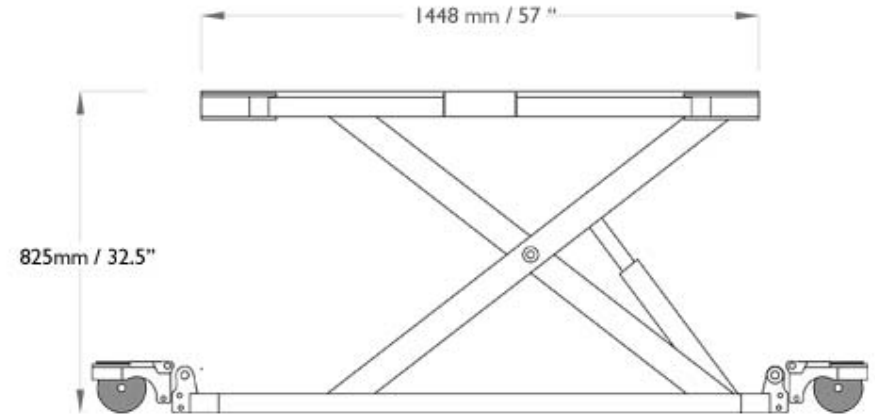

Features :

- CE Approval
- Swing Arm Locks
- Two Year Warranty
- Multiple Safety Features
- 115mm / 4.5 inches ground height
- Weather Resistant - Inside or Outside
- Australian Manufactured and Assembled
- No expensive electrical / installation costs
- Winner of many innovation and Safety Awards
- Used by all major Auto Brands around the globe

**series : Cartar
S.U.V Kit**

The Cartar S.U.V Kit is designed to work with both the Cartar Mobile and the Cartar Econo Lift range. With many of the unusual floor Pans and under-body lifting points in todays modern cars, the Cartar S.U.V kit gives that extra lift required for under body clearance. With this kit, the operator has the choice of two positions . Position A = 75 mm/3 inches above the Arm and position = B - 100 mm / 4 inches above the Arm. The S.U.V Kit comes in a set to accomodate 4 lifting points.



**series : Cartar
Platform Kit**

The Cartar Platform Kit provides an excellent Working Bench at variable heights to suit the the job at hand . With lift of 2.8 ton payload the Cartar Platform Kit. allows you to work in comfort on machinery and componanry that has excessive weight. . The Kit comes with the main deck, mounting bolts and 2 x drive on ramps.



**series : Cartar
Ramp Set**

The Cartar Ramp Kit is a simple , effective way to give your vehicle that extra 50 mm (2 inches) lift on lower than normal cars. With this extra height, no vehicle is too low for the Cartar FL Mobile to roll under .When used with the Cartar FL Mobile , machinery and componants can be moved to the high pressure washing department safely and with ease. Kit equals 2 x Ramps , Platform and mounting bolts.

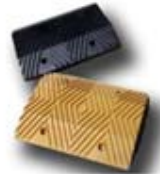

**series : Cartar
Spraybooth Kit**

The Cartar Spray Booth Kit is an integral part of the Cartar Mobile System .When implemented, these products have revolutionised the industries approach to the movement of vehicles in and out of the painting shop. The operator now is in the enviable position of being able to move a disassembled vehicle into and out of a spraybooth in a safe and cost effective manner. The financial benefits of combining the Cartar FL Mobile Lift with the Cartar Spraybooth Kit instead of a fixed and static lift in your spraybooth are numerous.



**series : Cartar
Econo Wheel Kit**

The Cartar FL Econo Lift becomes totally portable when fitted with the Econo Wheel Kit. Move your lift with ease to any position in your workshop. For that matter it can also be used outside in all weather conditions. Unlike many lifts that claim to be portable and require levering back on handles, and dragging hoses and canisters of oil, the Cartar FL Econo is totally self sufficient and glides along the factory floor. This is all possible because of the unique Cartar Econo Wheel set. This is an optional product.



**series : Cartar
Tow Kit**

The Cartar Tow Pack, when used with the Cartar FL Mobile Lift takes the movement and work flow of vehicles to a whole new level in the modern Auto Shop. The Tow Pack allows the operator to connect a loaded Cartar FL Mobile lift to a tow vehicle of choice and single handed, move that elevated Auto through the workshop. Now available are many battery powered towing devices that are ideally suited to work with the Cartar Tow Pack.



visit our Showroom Online : www.cartar.com.au

Showroom USA : www.cartarmobilelifts.com

Technical Specifications : model FLS

Specifications	FLS MOBILE
Retracted Height	115 mm / 4.5 inches (exclude 5' wheels)
Elevated Height	800 mm/ 32 inches
Length when fully Lowered	2 mtrs / 78.5 inches
Width when Arms Retracted	1050 mm / 41.5 inches
Power Source	Air Compressor
Maximum Lift Load	2,800 kg / 6,160 lbs
Shipping weight	285 kg / 628 lbs
Oil Grade	Hydraulic 46 grade
Oil Volume in Tank	5 ltrs / 1.3 gallons
Wheel turning circle	360 degrees
Leaf Chain	BL 534
Country of Manufacture	AUSTRALIA
Period of Warranty : (Conditional)	Two Years
Required Air Pressure	50 - 100 psi
Direction of Load	Front ,Rear or Side entry
Weather Resistant	Use inside or Outside
Power Pack and Oil Tank	Built in and Onboard
Installation Requirements	Nil
Onboard Electrics	Nil

All CARTAR Products are Quality Made for Long Life

Check the library of short video clips of the Cartar Mobile in action on our "You Tube" channel. Simply go to our web site and click onto the many titles and enjoy. Or go direct to "You Tube" and type in "Cartar"

